

Cast Iron Valves

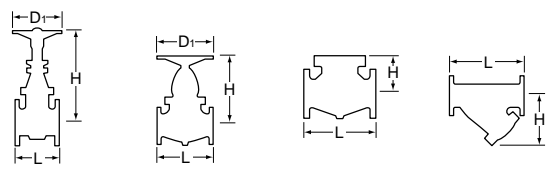

Design	TOYO Standard												
Type	Gate Valves						Globe Valve			Swing Check Valve			
Class	10K												
Fig.	410E			420E			405E			430E			
Size	L	H	D ₁	L	H	D ₁	L	H	D ₁	L	H		
50 (mm)	2"	178	319	180	178	357	180	203	318	200	203	153	
65	2 1/2"	190	350	180	190	412	180	216	333	200	216	162	
80	3"	203	401	200	203	482	200	241	361	200	241	176	
100	4"	229	457	250	229	569	250	292	390	250	292	220	
125	5"	254	523	280	254	672	280	330	439	300	330	226	
150	6"	267	602	300	267	783	300	356	477	300	356	307	
200	8"	292	711	360	292	985	355	495	542	360	495	325	
250	10"	330	842	400	330	1196	400	622	624	450	622	384	
300	12"	356	941	450	356	1390	450	698	735	500	698	426	
350	14"												
400	16"												
Material	Body	Cast Iron			Cast Iron			Cast Iron			Cast Iron		
	Stem/Pin	Brass			Brass			Brass			Brass		
	Disc	Cast Iron			Cast Iron			Cast Iron			Cast Iron		
	Seat	Bronze			Bronze			Bronze			Bronze		
Service conditions	120 water, non-shock 1.37MPa 120 oil, water, air 0.98MPa Saturated steam 0.20MPa												
Remarks	Body Marking: MSS standard indicating "125S 200WOG", Connection JIS B2239 10K-FF												

Design	TOYO Standard	
Type	Strainer	
Class	10K	
Fig.	450E	
Size	L	H
40 (mm)	1 1/2"	
50	2"	225
65	2 1/2"	273
80	3"	292
100	4"	352
125	5"	391
150	6"	470
200	8"	543
250	10"	660
300	12"	762
350	14"	
400	16"	
Material	Body	Cast Iron
	Screen	SUS304 (SUS316 Screen available)
Service conditions	120 water, non-shock 1.37MPa 120 oil, water, air 0.98MPa Saturated steam 0.69MPa	
Remarks	Body Marking: MSS standard	

Trim Combination (JIS Standard)

Fig.	Stem/Pin	Disc	Seat
425J	Brass	C.I./Same material as Seat	Bronze
425JS	13%Cr		13%Cr
425JU	SUS304		SUS304
405J	Brass		Bronze
405JS	13%Cr		13%Cr
405JU	SUS304		SUS304
435J	Brass		Bronze
435JS	13%Cr		13%Cr
435JU	SUS304		SUS304

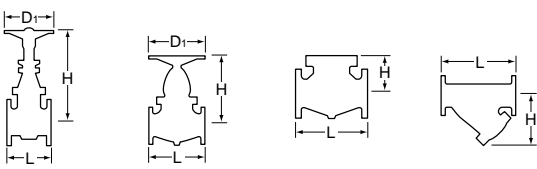

JIS Cast Iron Valves

Design		JIS Standard											
Type		Gate Valves									Globe Valve		
Class		10K			5K			10K					
		JIS B2031/Non-rising			JIS B2031/Rising			JIS B2031/Rising			JIS B2031		
Fig.		415J			424J			425J/JS/JU			405J/JS/JU		
Size		L	H	D ₁	L	H	D ₁	L	H	D ₁	L	H	D ₁
40(mm)	1 1/2"	*165	285	160				*165	306	160	190	260	160
50	2"	180	313	180	160	328	160	180	343	180	200	277	180
65	2 1/2"	190	344	180	170	382	180	190	389	180	220	307	180
80	3"	200	401	200	180	436	180	200	462	200	240	353	230
100	4"	230	444	250	200	532	200	230	547	250	290	404	280
125	5"	250	517	280	220	627	230	250	648	280	360	454	300
150	6"	270	577	300	240	726	250	270	759	300	410	533	360
200	8"	290	693	360	260	919	280	290	956	360	500	642	450
250	10"	330	814	400	300	1134	360	330	1168	400	*620	665	450
300	12"	350	925	450				350	1363	450	*700	883	500
350	14"							*381	1560	500			
Material	Body	Cast Iron			Cast Iron			Cast Iron			Cast Iron		
	Stem	Brass			Brass			Brass/SUS403/SUS304			Brass/SUS403/SUS304		
	Disc	Cast Iron or same material as seat			Cast Iron or same material as seat			Cast Iron or same material as seat			Cast Iron or same material as seat		
	Seat	Bronze			Bronze			Bronze/SUS403/SUS304			Bronze/SUS403/SUS304		
Service conditions	120 water, non-shock 1.37MPa 120 oil, water, air 0.98MPa Saturated steam 0.20MPa			120 water, non-shock 0.69MPa 120 oil, water, air 0.49MPa Saturated steam 0.20MPa			120 water, non-shock 1.37MPa 120 oil, water, air 0.98MPa Saturated steam 0.69MPa			120 water, non-shock 1.37MPa 120 oil, water, air 0.98MPa Saturated steam 0.69MPa			
Remarks	*TOYO Standard						*TOYO Standard			*TOYO Standard			

Design		JIS Standard				TOYO Standard			
Type		Swing Check Valves				Strainer			
Class		10K							
		JIS B2031				437J		450	
Fig.		435J/JS/JU				437J		450	
Size		L	H	L	H	L	H	L	H
40(mm)	1 1/2"	*190	106						
50	2"	200	111	200	111	250	167		
65	2 1/2"	220	121	220	121	285	193		
80	3"	240	145	240	145	315	210		
100	4"	290	165	290	165	370	256		
125	5"	360	207	360	207	450	318		
150	6"	410	225	410	225	410	364		
200	8"	500	268	500	268	600	507		
250	10"	*620	315			740	600		
300	12"					850	673		
350	14"					950	757		
400	16"					1050	845		
Material	Body	Cast Iron				Cast Iron		Cast Iron	
	Pin	Brass/SUS403/SUS304				SUS304		Screen SUS304	
	Disc	Cast Iron or same material as seat				Cast Iron or same material as seat			
	Seat	Bronze/SUS403/SUS304				SUS304			
Service conditions	120 water, non-shock 1.37MPa 120 oil, water, air 0.98MPa Saturated steam 0.69MPa				120 water, non-shock 1.4MPa 120 oil, water, air 1.0MPa Saturated steam 0.69MPa		120 water, oil, air below size 200 1.1MPa above size 250 0.7MPa Saturated steam below size 200 0.7MPa above size 250 0.20MPa		
Remarks	*TOYO Standard				c/w counter weight		Perforated screen equivalent to 12-16 meshes		

- Rusty Water-Proof Series - JIS Nylon Lined Cast Iron Valves

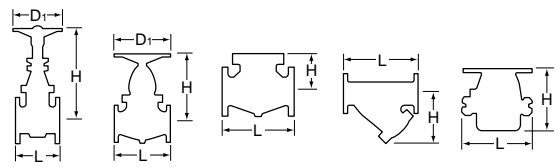

Design		JIS Standard										
Type		Gate Valves						Globe Valve			Check Valve	
Class		5K			10K			10K				
		JIS B2031			JIS B2031			JIS B2031			JIS B2031	
Fig.		419			429			409			439	
Size		L	H	D ₁	L	H	D ₁	L	H	D ₁	L	H
50 (mm)	2"				180	343	180					
65	2 1/2"	170	382	180	190	389	180	220	307	180	220	121
80	3"	180	436	180	200	462	200	240	353	230	240	145
100	4"	200	532	200	230	547	250	290	404	280	290	165
125	5"	220	627	230	250	648	280	360	454	300	360	207
150	6"	240	726	250	270	759	300	410	533	360	410	225
200	8"	260	919	280	290	956	360	500	642	450	500	268
250	10"	300	1134	360	330	1168	400					
300	12"				350	1363	450					
Material	Body	Cast Iron/Nylon Lined			Cast Iron/Nylon Lined			Cast Iron/Nylon Lined			Cast Iron/Nylon Lined	
	Stem	Brass			Brass			Brass			Brass	
	Disc	Bronze			Bronze			Bronze			Bronze	
	Seat	Bronze			Bronze			Bronze			Bronze	
Service conditions	60	water, non-shock 0.69MPa			60 water, non-shock 1.37MPa							
	60	oil, water, air 0.49MPa			60 oil, water, air 0.98MPa							
Remarks												

Design		TOYO Standard			
Type		Strainer		Foot Valve	
Class		10K			
Fig.		459		469	
Size		L	H	L	H
65 (mm)	2 1/2"	285	193	173	161
80	3"	315	210	193	188
100	4"	370	256	236	229
125	5"	450	318	271	289
150	6"	510	364	305	335
200	8"	600	507	388	449
250	10"	740	600		
300	12"	850	673		
Material	Body	Cast Iron/Nylon Lined		Cast Iron/Nylon Lined	
	Screen	SUS304		Seat	EPDM
				Ball	Polycarbonate
Service conditions	60	water 0.7MPa		60 water 0.2MPa	
Remarks					

Features

Toyo Nylon Lined Cast Iron Valves conform to JIS B2031.(Gate, Globe & Check Valves)

There is no RUSTY-WATER accrual from valves since all surface of cast iron in direct contact with water is lined by Nylon 11.

Nylon 11 can be used for a wide range of fluid with having its corrosion resistance, sea water-proof nature & chemical resistance. (Please consult Toyo sales staff for details.

Nylon 11 can be used in food industries.

Electrolytic corrosion does not occur, as Nylon 11 is an insulator.

Specifications

Lining material

Nylon 11 Special Grade Resin (Heat-resistance)

Color : White Film thickness : Above 300 μ m

Service temperature

Addicted service temperature : 0 ~ 60

Trim material

Standard trim material for gate, globe & swing check valves

Seat : CAC406(BC6)	Stem : Brass
--------------------	--------------

*Screen material of a strainer is SUS304.

Special Valves



Valves with special functions

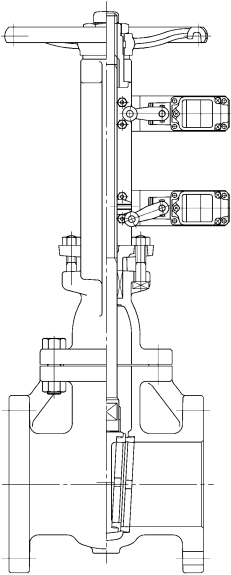
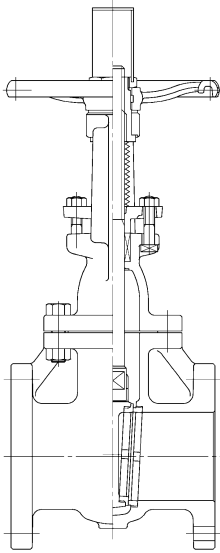
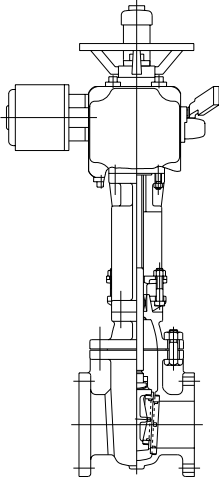
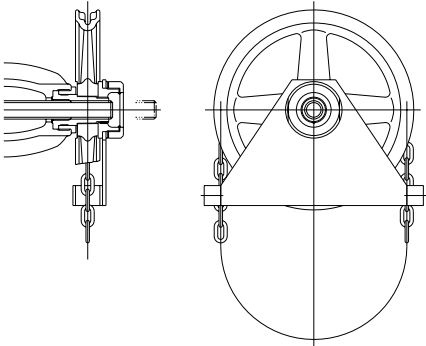
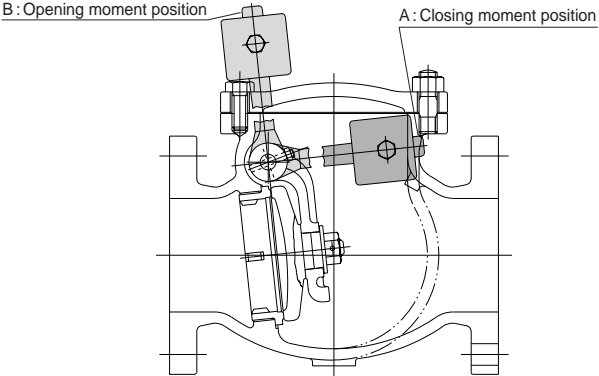

Toyo Valve has much experience in not only standard products but also products with special functions. Please consult Toyo sales staff or our local agent for details.

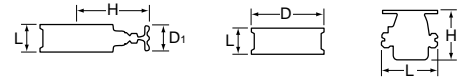
Limit switches	Stem cap & cover	Moterized valve
<p data-bbox="140 412 580 506">It is attached at open, closed or both open and closed positions for remote surveillance.</p> 	<p data-bbox="603 412 1043 506">Protection of stem from dust, foreign objects, etc. in order to avoid a poor operation.</p> 	<p data-bbox="1066 412 1506 568">Toyo has much and long experience to supply motorized valves with high quality. On request, valves can be provided with each maker's actuator like LIMITORQUE, ROTORK, SEIBU, etc.</p> 
Chain handle	Counter-weight check valve	
<p data-bbox="140 1202 667 1234">Easy operation for a valve on elevated piping line.</p> 	<p data-bbox="836 1202 1506 1391">By adjusting the counter-weight to the closed moment, water-hammer is restrained by quicker closing and excellent seat sealing capability is acquired. Balance of disc is maintained by adjusting the counter-weight to the open moment, the flow with low pressure is facilitated and opening and closing disc is made smooth.</p> 	

Dual Plate Check / Ball Foot



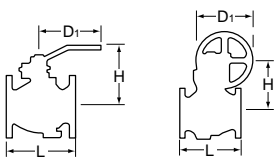

Design	TOYO Standard									
Type	Dual Plate Check Valves									
Class	10K							150		
										
Fig.	365			440				442F		
Size	L	H	D ₁	L	H	D ₁	L	D		
40 (mm)	1 1/2"	54	132	63	54	128	55			
50	2"	56	140	70	56	143	70	54	105	
65	2 1/2"	56	150	70	56	150	70	54	124	
80	3"	59	156	70	59	156	70	57	137	
100	4"	66	169	70	66	169	70	64	175	
125	5"	72	183	70	72	183	70	70	197	
150	6"	78	212	80	78	216	80	76	222	
200	8"	96	240	80	96	243	80	95	279	
250	10"	109	289	90	109	290	90	108	340	
300	12"	145	316	90	145	315	90	143	410	
350	14"				184	330	90	184	451	
400	16"				191	355	90	191	514	
450	18"				204	388	90	203	549	
Material	Body	Bronze			Cast Iron			Cast Iron		
	Plate	Bronze			Bronze			Bronze		
	Seat	NBR			NBR			NBR		
Service conditions	80 water, non-shock 1.4MPa						1.03MPa (150psi) 80 water			
	80 water, oil, air 1.0MPa									
Remarks	FPM or EPDM seat available									
	By-pass valve mounted									

Design	TOYO Standard				
Type	Ball Foot Valves				
Class	10K				
					
Fig.	097		461		
Size	L	H	L	H	
40 (mm)	1 1/2"	133	121		
50	2"	148	147		
65	2 1/2"			173	161
80	3"			193	188
100	4"			236	229
125	5"			271	289
150	6"			305	335
200	8"			388	449
Material	Body	Bronze		Cast Iron	
	Seat	EPDM		EPDM	
	Ball	Polycarbonate		Polycarbonate	
Service conditions	70 water 0.20MPa (29psi)				
Remarks					

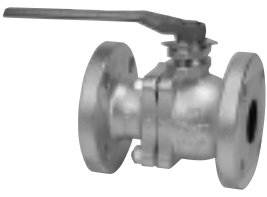

Cast Iron Ball Valves

Design	TOYO Standard						
Type	Ball Valves						
Class	10K						
							
	Full bore			Full bore			
Fig.	470L			470G			
Size		L	H	D ₁	L	H	D ₁
15 ^(mm)	1/2"	110	102	130			
20	3/4"	120	105	130			
25	1"	130	124	160			
32	1 1/4"	140	130	160			
40	1 1/2"	165	115	230			
50	2"	180	120	230			
65	2 1/2"	190	155	400			
80	3"	200	165	400			
100	4"	230	200	460			
125	5"	300	220	460	300	312	310
150	6"	340	295	1000	340	337	310
200	8"	450	355	1500	450	414	360
Material	Body	Cast Iron			Cast Iron		
	Stem	SUS403			SUS403		
	Disc	SUS304 or SCS13A			SUS304 or SCS13A		
	Seat	PTFE			PTFE		
Service conditions	See P-T rating at page 26						
Remarks	ASME Class 125 flanged ends available upon request						

Toyo Dual Plate Check Valve

A water hammer is prevented (Silent Check Type)

By action of the coil spring built in a valve, plates are gently opened at the time of starting a pump or it closes quickly when a pump stops. For this reason, a water hammer is prevented and generating a shock pressure is controlled.

It is compact.

A small and lightweight wafer body. As compared with a swing check, the face-to-face dimension is about 1/4 and the weight is about 1/5. Piping work is easy, and attachment space for installation is also small.

By-pass piping is unnecessary. (Fig. 365 and 440)

Since the by-pass valve is built in, the by-pass piping for discharge of the fluid in a pipe or priming when starting a pump are unnecessary. It is a big merit on design and construction.

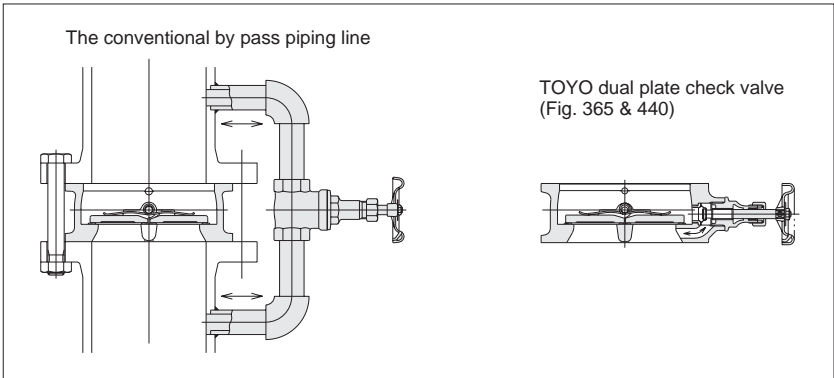
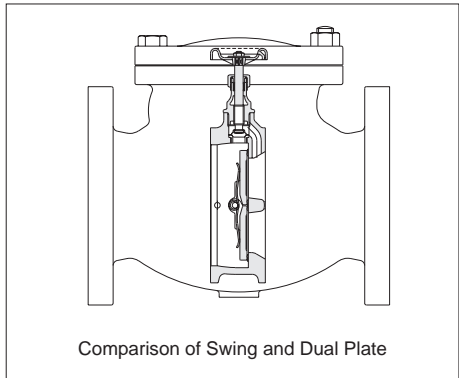

Pressure-Temperature Ratings

Bronze and Brass Valves (Extracted from MSS SP-80)

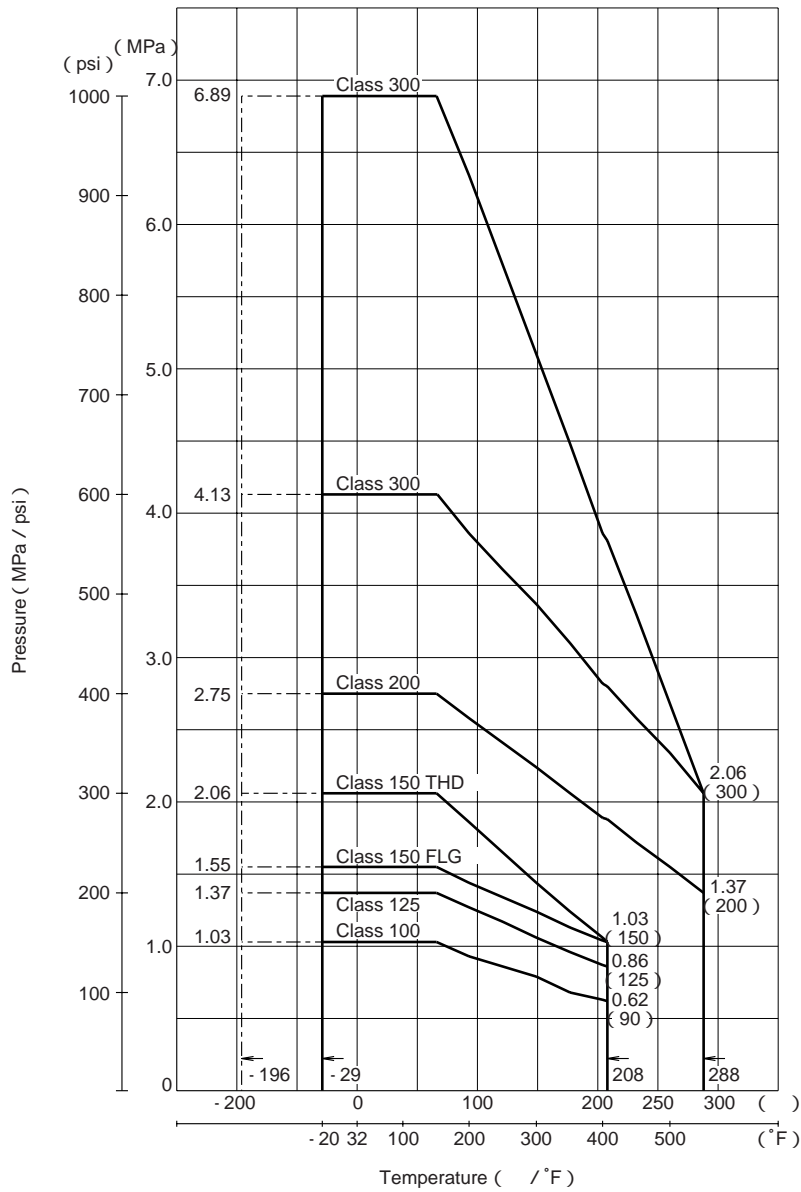

Pressure-Temperature Ratings

Service temperature			100		125		150				200		300			
			THD		THD		FLG		FLG		THD		THD			
	°F	MPa	psi	MPa	psi	MPa	psi	MPa	psi	MPa	psi	MPa	psi	MPa	psi	
-29 - 66	-20 - 150	1.03	150	1.37	200	2.06	300	1.55	225	2.75	400	4.13	600	6.89	1000	
93	200	0.93	136	1.27	185	1.86	270	1.44	210	2.58	375	3.86	560	6.34	920	
121	250	0.86	126	1.17	170	1.65	240	1.34	195	2.41	350	3.61	525	5.72	830	
149	300	0.79	116	1.06	155	1.44	210	1.24	180	2.24	325	3.37	490	5.10	740	
177	350	0.68	100	0.96	140	1.24	180	1.13	165	2.06	300	3.10	450	4.48	650	
204	400	0.63	92	-	-	-	-	-	-	1.89	275	2.82	410	3.86	560	
208	406	0.62	90	0.86	125	1.03	150	1.03	150	-	-	-	-	-	-	
232	450	-	-	-	-	-	-	-	-	1.72	250	2.58	375	3.30	480	
260	500	-	-	-	-	-	-	-	-	1.55	225	2.34	340	2.68	390	
288	550	-	-	-	-	-	-	-	-	1.37	200	2.06	300	2.06	300	
Saturated steam		0.68	100	0.86	125	1.03	150	1.03	150	1.37	200	2.06	300	2.06	300	
Test pressure	shell	1.55	225	2.06	300	3.10	450	2.41	350	4.13	600	6.20	900	10.34	1500	
	seat	0.55	80	0.55	80	0.55	80	0.55	80	0.55	80	0.55	80	0.55	80	

NOTE: Class 100 outside of MSS SP-80

Pressure-Temperature Ratings

Ball Valves

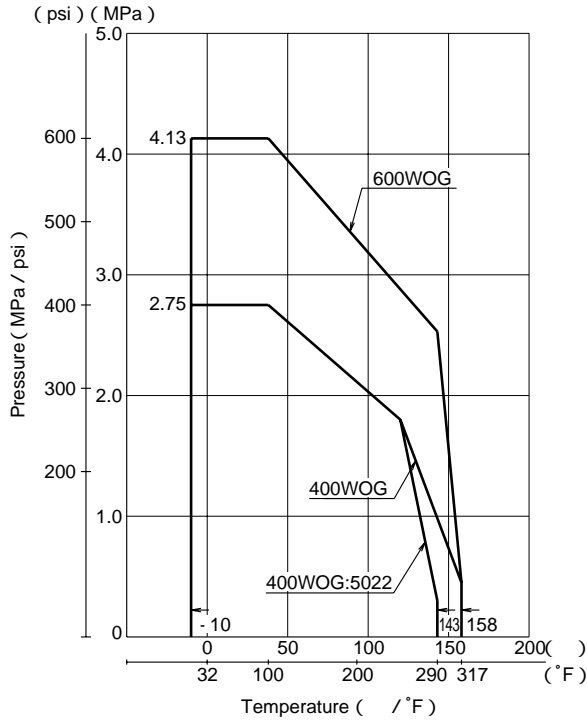

Pressure-Temperature Ratings

Class	WOG 38		Test pressure			
	(3°F)		shell (water)		seat (air)	
	MPa	psi	MPa	psi	MPa	psi
400 WOG	2.75	400	4.13	600	0.55	80
600 WOG	4.13	600	6.20	900	0.55	80

Do not use products in flammable or toxic gas.

Solder

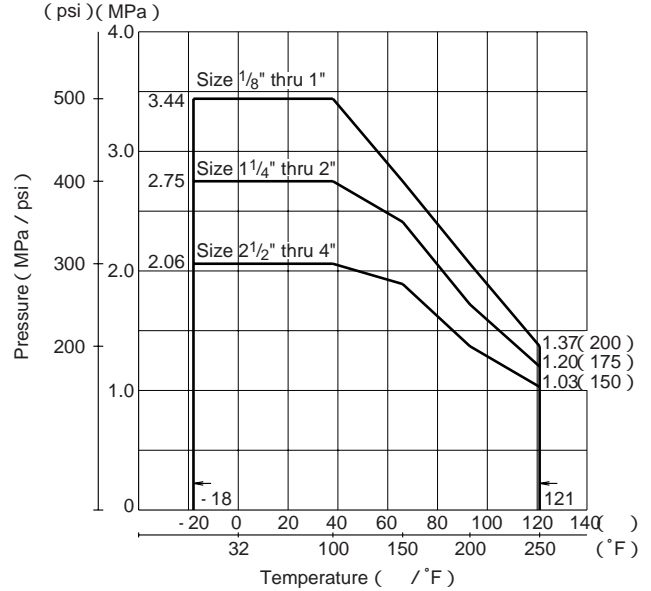

Pressure-Temperature Ratings

Joint material	Working temperature		Maximum working gage pressure						Test pressure	
	°F	°C	1/8" thru 1"		1/4" thru 2"		2 1/2" thru 4"		shell water	seat air
			MPa	psi	MPa	psi	MPa	psi		
ASTM B32 Alloy Grade 50A [Notes (1), (2)]	38	100	1.37	200	1.20	175	1.03	150	300psi	80psi
	66	150	1.03	150	0.86	125	0.68	100		
	93	200	0.68	100	0.62	90	0.51	75		
ASTM B32 Alloy Grade 95TA [Note (2)]	38	100	3.44	500	2.75	400	2.06	300	2.06	0.55
	66	150	2.75	400	2.41	350	1.89	275		
	93	200	2.06	300	1.72	250	1.37	200		
	121	250	1.37	200	1.20	175	1.03	150		

Notes: (1) The Safe Drinking Water Act Amendment of 1986 prohibits the use in potable water systems of any solder having a lead content in excess of 0.2%.

(2) The safe working pressure-rating for a solder end valve is restricted to the lower pressure-rating.

JIS Standard Valves

Bronze Gate, Globe and Check Valves (JIS B2011)

Service temperature	Maximum working pressure (MPa)	
	5K	10K
Water, Non-shock at less than 120	0.7	1.4 1.18(*3)
Oil, gas(*4), air, water at less than 120	0.5	1.0 0.85(*3)
Saturated steam(*1)	0.3 0.2(*2)	1.0 0.7(*2)
Test pressure	shell	water
	seat	air
		1.1 2.1 0.6 0.6

(*1) Not applied to solder ends

(*2) Applicable to gate valves

(*3) Applicable to solder ends in size 32mm (1.1/4") and larger

(*4) Do not use products in flammable or toxic gas

Gray Cast Iron Gate, Globe and Check Valves (JIS B2031)

Service temperature	Maximum working pressure (MPa)	
	5K	10K
Water, Non-shock at less than 120 (*1)	0.69	1.37
Oil, gas(*3), air, water at less than 120 (*1)	0.49	0.98
Saturated steam	0.20	0.69 0.20(*2)
Test pressure	shell	water
	seat	air
		1.1 2.1 0.6 0.6

(*1) The max. working temperature for nylon lined valves is restricted to 60

(*2) Inside screw gate valves and pressed seat rings only

(*3) Do not use products in flammable or toxic gas

Pressure-Temperature Ratings

Cast Iron Valves (Extracted from MSS SP-70, 71 & 85)

Class 125 Gate, Globe and Check Valves

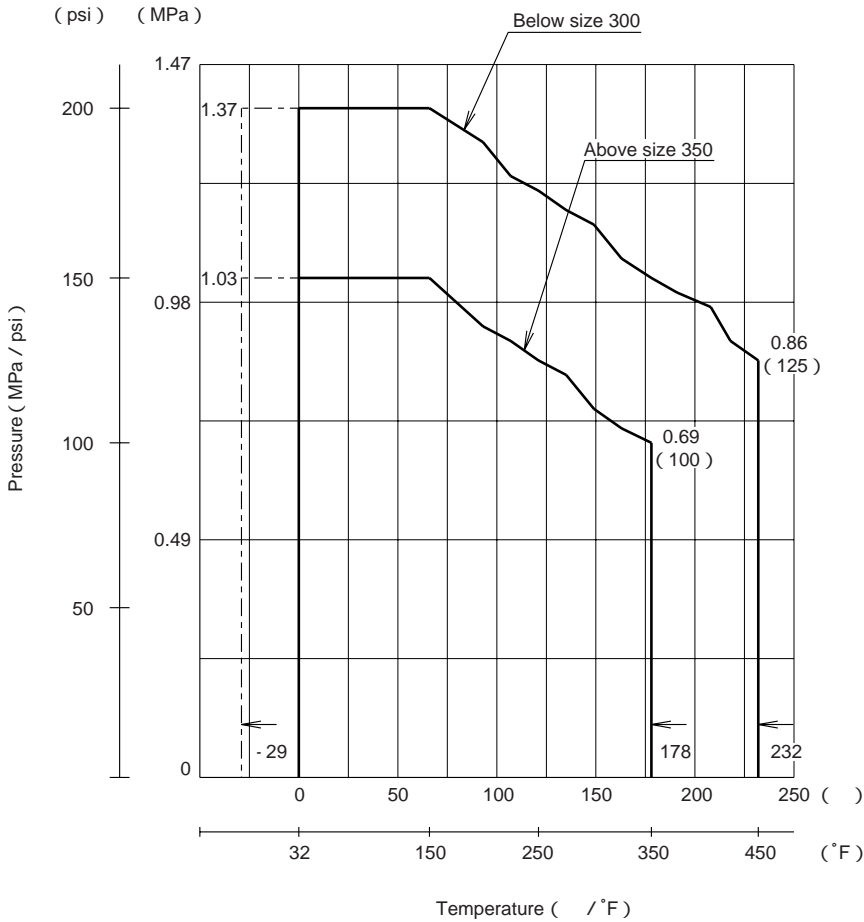

Pressure-Temperature Ratings

Temperature	Size 50 thru 300		Above size 350			
	° F	MPa	psi	MPa	psi	
-29 - 66	-20 - 150	1.37	200	1.03	150	
93	200	1.31	190	0.93	135	
107	225	1.24	180	0.90	130	
121	250	1.21	175	0.86	125	
135	275	1.17	170	0.83	120	
149	300	1.14	165	0.76	110	
163	325	1.07	155	0.72	105	
178	350	1.03	150	0.69	100	
191	375	1.00	145			
208	400	0.97	140			
218	425	0.90	130			
232	450	0.86	125			
Saturated steam		0.86	125	0.68	100	
Test pressure	shell	water	2.41	350	1.83	265
	seat	air	0.55	80	0.55	80

10K Cast Iron Ball Valves

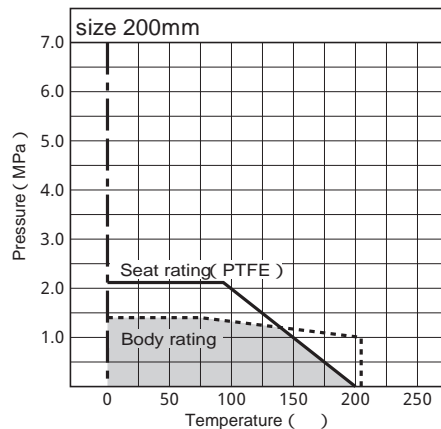
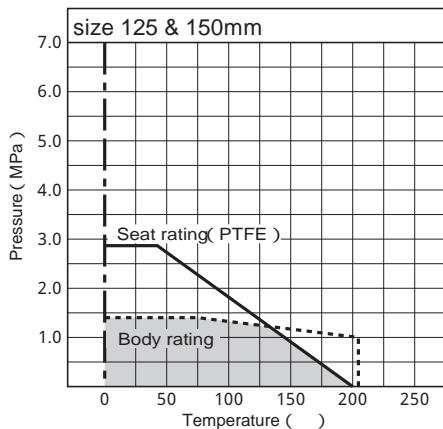
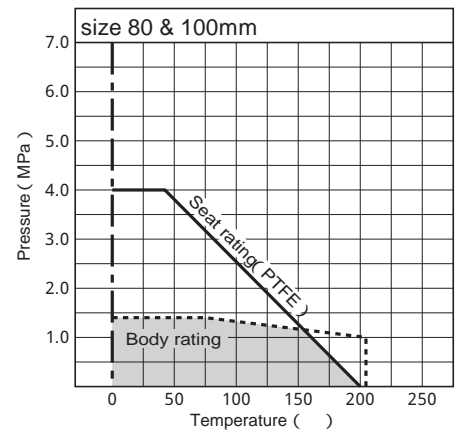
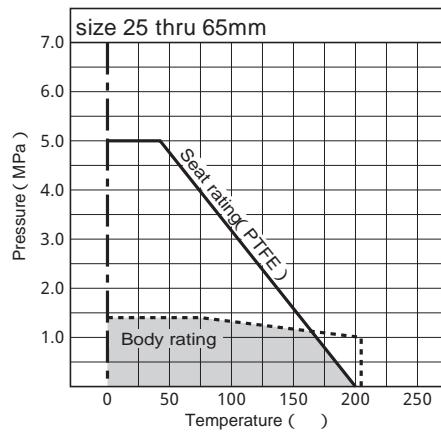
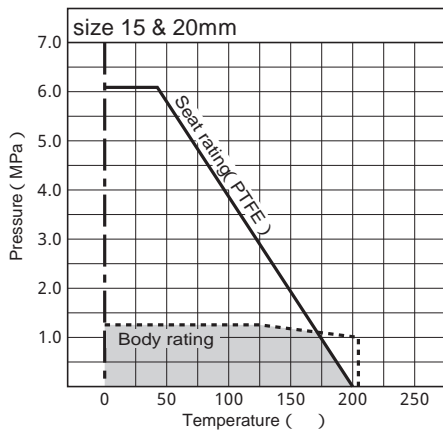

Cv Value

The Cv value – which is used by TOYO VALVE to indicate the capacity of a valve – is a flow rate represented in terms of U.S. gallons per minute when clear water at 60°F flows through a valve, in which the differential pressure between its outlet and inlet is kept at 1 psi – 6.89kPa.

The Cv value can be determined by experiment, and the relation between the Cv value and the flow rate or pressure drop, when the fluid is water.

In case of water, the pressure drop or the flow rate can be obtained by the following formulas.

$$P = 0.134 \frac{Q^2 G_L}{C_v^2}$$

P = pressure drop (MPa)

Q = flow rate

$$Q = 2.735 C_v \sqrt{\frac{P}{G_L}}$$

G_L = specific gravity of fluid when setting water to 1

C_v = Cv value

Cast Bronze Valves

Valve type		GATE	GLOBE		ANGLE	CHECK		BALL	STRAINER
Nominal size						LIFT	SWING	FULL BORE	
mm	Inch	206A	210A	211A/213A	260A	230A	236A	5090	380A
8	1/4	2.8					1.5		
10	3/8	5.7	2	2	2.5	2	2.8		
15	1/2	15	3	3.5	4	3.5	5	26	4.5
20	3/4	18	4.5	6.5	7.5	6.5	9	46	7.5
25	1	29	8.5	12	13	11	20	80	14
32	1 1/4	59	16	21	23	19	36	105	19
40	1 1/2	120	23	30	34	28	51	141	30
50	2	190	38	49	55	46	92	215	47
65	2 1/2	335	64	87	97	81	162		
80	3	486	93		166	123	247		
100	4	772				163			

Cast Iron Valves

Valve type		GATE	GLOBE	CHECK		BALL	STRAINER	BALL FOOT
Nominal size				SWING	DUAL PLATE	FULL BORE		
mm	Inch	410E/420E	405E	430E	440	470	450E	461
15	1/2					26		
20	3/4					53		
25	1					95		
32	1 1/4					165		
40	1 1/2	129	33	54	40	235		17
50	2	216	55	110	56	485	51	28
65	2 1/2	345	88	143	93	730	80	44
80	3	495	126	206	157	1240	116	75
100	4	875	224	440	325	2250	205	125
125	5	1370	350	575	540	3550	325	190
150	6	1920	485	830	815	5200	465	330
200	8	3600	920	1500	1450	9900	845	380
250	10	5680	1450	2370	2350		1350	
300	12	8290	2120	3470	3640		2080	
350	14				5480			
400	16				7930			